

Gretton Litter Bin

Galvanised, Galvanised & Colour or Stainless

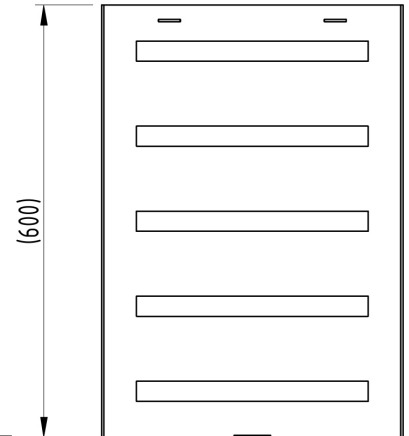

The Gretton Litter Bin is ideal for use in high traffic public areas such as high streets and parks. With a simple and stylish design, this bin is designed to complement the Gretton and Triton ranges of street furniture. Supplied with a galvanised steel liner as standard, the base of the bin can be bolted onto the floor for added security.

The Gretton Litter Bin is supplied in galvanised mild steel, or stainless steel. Galvanised and powder coated is an optional extra (RAL number must be stated at time of order).

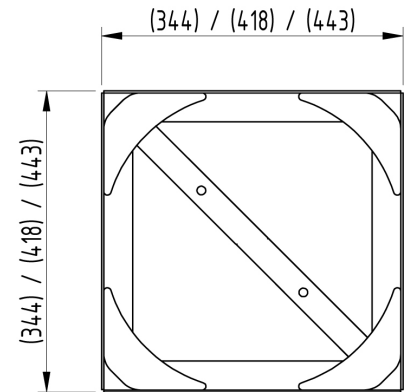

<u>Part Number</u>	<u>Description</u>	<u>Weight (kg)</u>
138 118 091	45L Galvanised	26kg
138 118 092	45L Galvanised & Colour	26kg
138 118 093	45L Stainless Steel Grade 304	26kg
138 118 094	75L Galvanised	34kg
138 118 095	75L Galvanised & Colour	34kg
138 118 096	75L Stainless Steel Grade 304	34kg
138 118 097	90L Galvanised	36kg
138 118 098	90L Galvanised & Colour	36kg
138 118 099	90L Stainless Steel Grade 304	36kg

Product details

- 600mm height
- 45L, 75L or 90L Capacity
- Price excludes fixing down bolts
- Complete with a galvanised steel liner

Installation & use

Bases are pre-drilled ready for bolting down onto a suitable concrete foundation by means of two 12mm anchor bolts. This product is guaranteed for 12 months (if installed and used correctly)