

# Gretton Bench 300 1200mm Galvanised or Galvanised & Colour

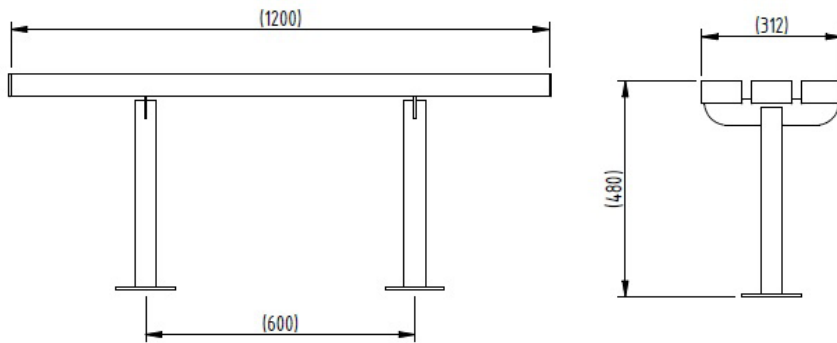

With a simple and traditional design, the Gretton Bench 300 is perfect for use in busy public spaces like schools, parks and playgrounds. Manufactured from galvanised mild steel, this robust range will complement any site, looking good for many years with only minimal maintenance.

The Gretton Bench 300 is supplied in galvanised mild steel. Galvanised and powder coated is an optional extra (RAL number must be stated at time of order).

Available concrete in and bolt down.



<u>Part Number</u>	<u>Description</u>	<u>Weight (kg)</u>
138 117 080R	Gretton Bench 300, Galvanised - Concrete In	27kg
138 117 080RC	Gretton Bench 300, Galvanised & Colour - Concrete In	27kg
138 117 080	Gretton Bench 300, Galvanised - Bolt Down	27kg
138 117 080C	Gretton Bench 300, Galvanised & Colour - Bolt Down	27kg

## Product details

- 1200mm x 312mm x 480mm (length x width x height)
- 480mm (seat height)
- Complete with plastic end caps
- Concrete in 300mm (below ground)
- Round flange plate – 133mm x 5mm
- Each bench requires 6 x 12mm bolts

## Installation & use

Supplied fully welded for easy installation on site.

Bolt down versions require bolting to an appropriate concrete surface by means of 12mm bolts.

Concrete in versions require an excavated hole for installation.

Clean off any concrete splashes after installation. Always allow sufficient time for concrete to cure before usage.

These products are guaranteed for 12 months (if installed and used correctly).

# Gretton Bench 600 1200mm Galvanised or Galvanised & Colour

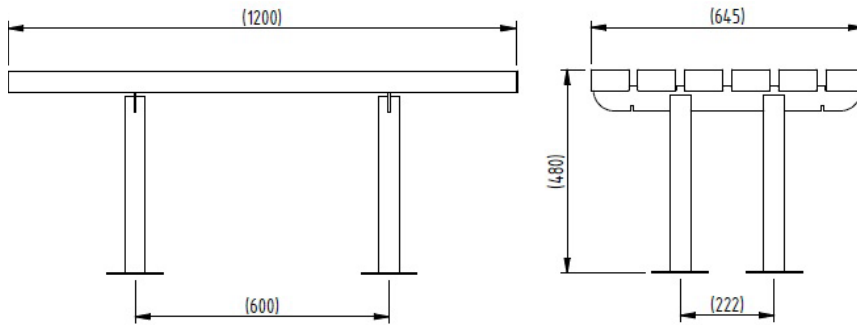

With a simple and traditional design, the Gretton Bench 600 is perfect for use in busy public spaces like schools, parks and playgrounds. Manufactured from galvanised mild steel, this robust range will complement any site, looking good for many years with only minimal maintenance.

The Gretton Bench 600 is supplied in galvanised mild steel. Galvanised and powder coated is an optional extra (RAL number must be stated at time of order).

Available concrete in and bolt down.



<u>Part Number</u>	<u>Description</u>	<u>Weight (kg)</u>
138 117 081R	Gretton Bench 600, Galvanised - Concrete In	55kg
138 117 081RC	Gretton Bench 600, Galvanised & Colour - Concrete In	55kg
138 117 081	Gretton Bench 600, Galvanised - Bolt Down	55kg
138 117 081C	Gretton Bench 600, Galvanised & Colour - Bolt Down	55kg

## Product details

- 1200mm x 645mm x 480mm (length x width x height)
- 480mm (seat height)
- Complete with plastic end caps
- Concrete in 300mm (below ground)
- Round flange plate – 133mm x 5mm
- Each bench requires 12 x 12mm bolts

## Installation & use

Supplied fully welded for easy installation on site.

Bolt down versions require bolting to an appropriate concrete surface by means of 12mm bolts.

Concrete in versions require an excavated hole for installation.

Clean off any concrete splashes after installation. Always allow sufficient time for concrete to cure before usage.

These products are guaranteed for 12 months (if installed and used correctly).